

Example Model (20 marks)

Consider the partial MO diagram of H_2NBH_2 below. Do **NOT** redraw the whole MO diagram.

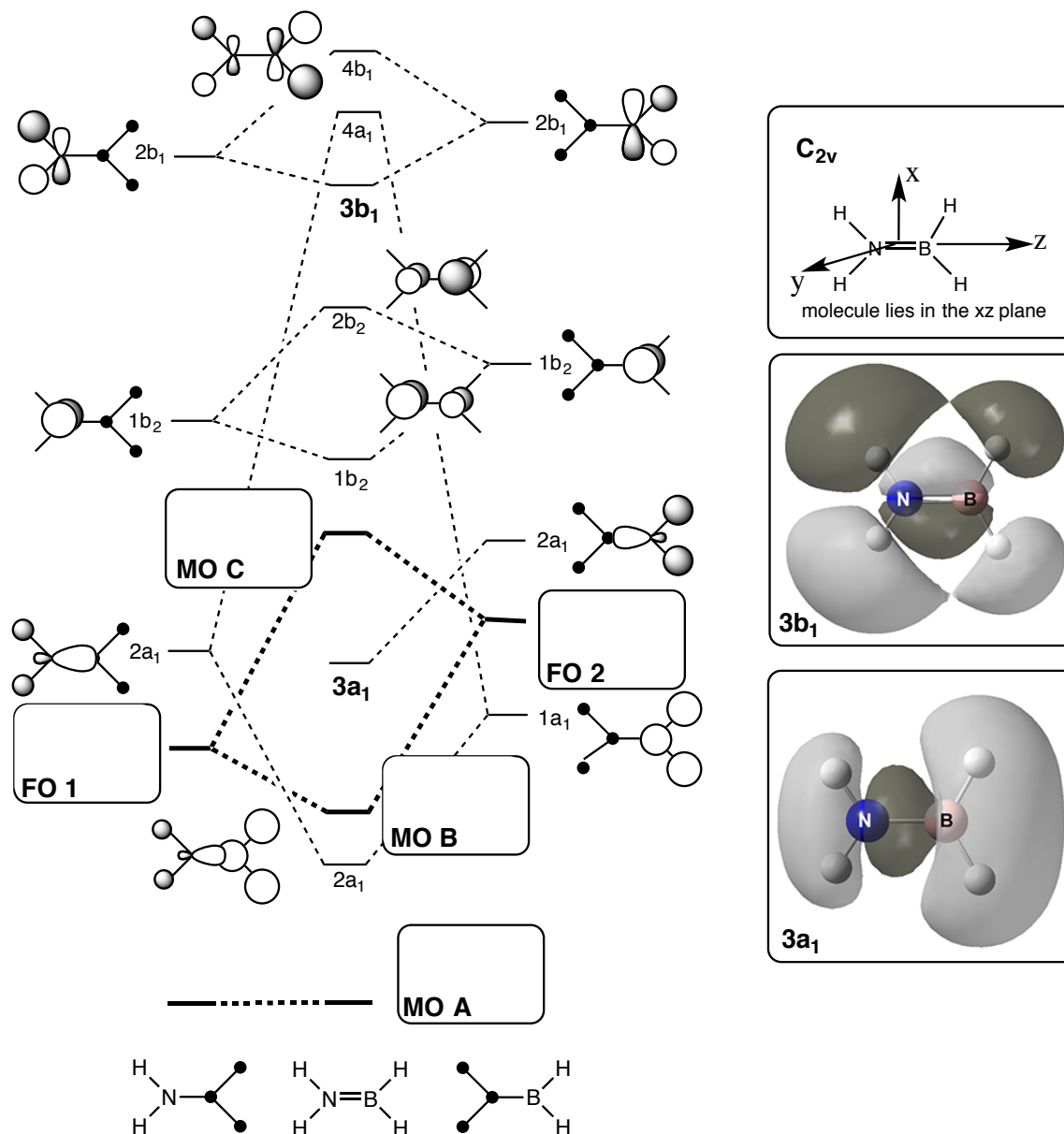

1. **Draw** and **identify** the symmetry of the missing fragment orbitals **FO 1** and **FO 2**, and the missing MOs **MO A**, **MO B** and **MO C**.

(8 marks)

2. **Draw** the linear combination of atomic orbitals (LCAO) diagram for the $3a_1$ and $3b_1$ MOs. Use your diagram to **identify** and **explain** key features that are important in evaluating the character of **these** MOs.

(8 marks)

3. **List** the MOs that contribute to the B-H σ -bonds, **explain** why you selected these MOs.

(4 marks)

Consider the partial MO diagram of H_2NBH_2 below. Do **NOT** redraw the whole MO diagram.

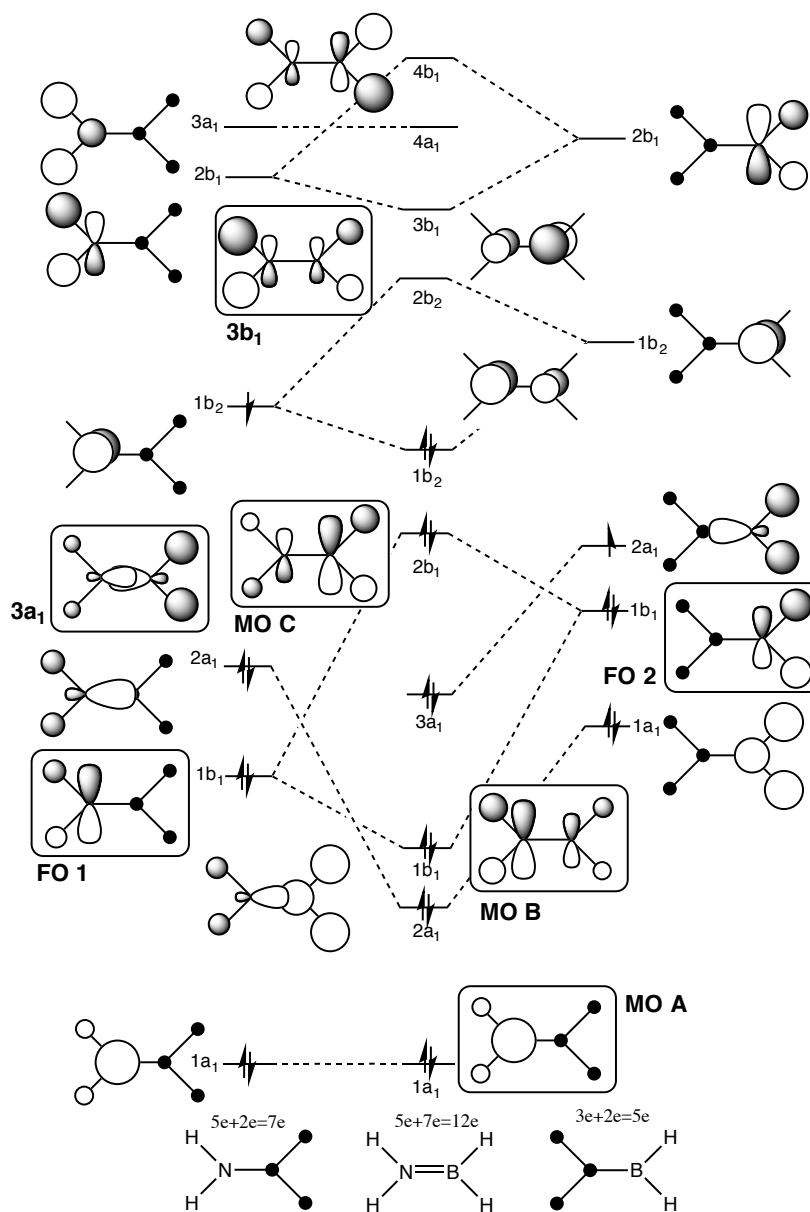

1. **Draw and identify** the symmetry of missing fragment orbitals **FO 1** and **FO 2**, and the missing MOs **MO A**, **MO B** and **MO C**.

(8 marks)

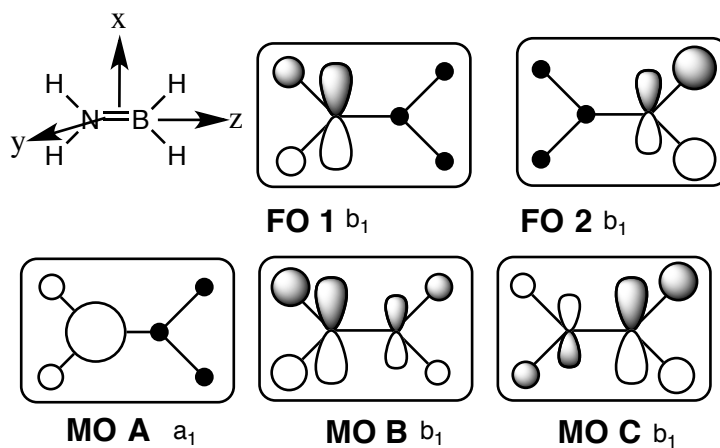

"shape" of orbitals right (4 marks), relative sizes correct (2 marks), symmetry labels (2 mark) identified directly from the MO

- FO1 must have a larger N pAO contribution as N is more electronegative than H
- FO2 must have a larger H sAO contribution as H is more electronegative than B
- MOA must have only a contribution from the NH₂ fragment, this is both a FO and MO
- MOB must have a larger contribution from the NH₂ fragment as this is lower in energy, and this MO is bonding between these two fragments
- MOC must have a larger contribution from the higher energy BH₂ fragment as this is an antibonding MO with respect to these two fragments.

2. Draw a linear combination of atomic orbitals (LCAO) diagram for the 3a₁ and 3b₁ MOs. Use your diagram to identify and explain key features that are important in evaluating the character of these MOs.

(8 marks)

shape of the contributions (2 marks)

relative size of the AO contributions (2 marks)

explanations must include comments on the following (4 marks)

- through space vs through bond ie distance dependence of overlap
- nodes and relative importance of nodes as through atoms or bonds or space
- s-s vs sp and sigma vs pi type overlap of orbitals
- strong vs weak overlap/distance arguments

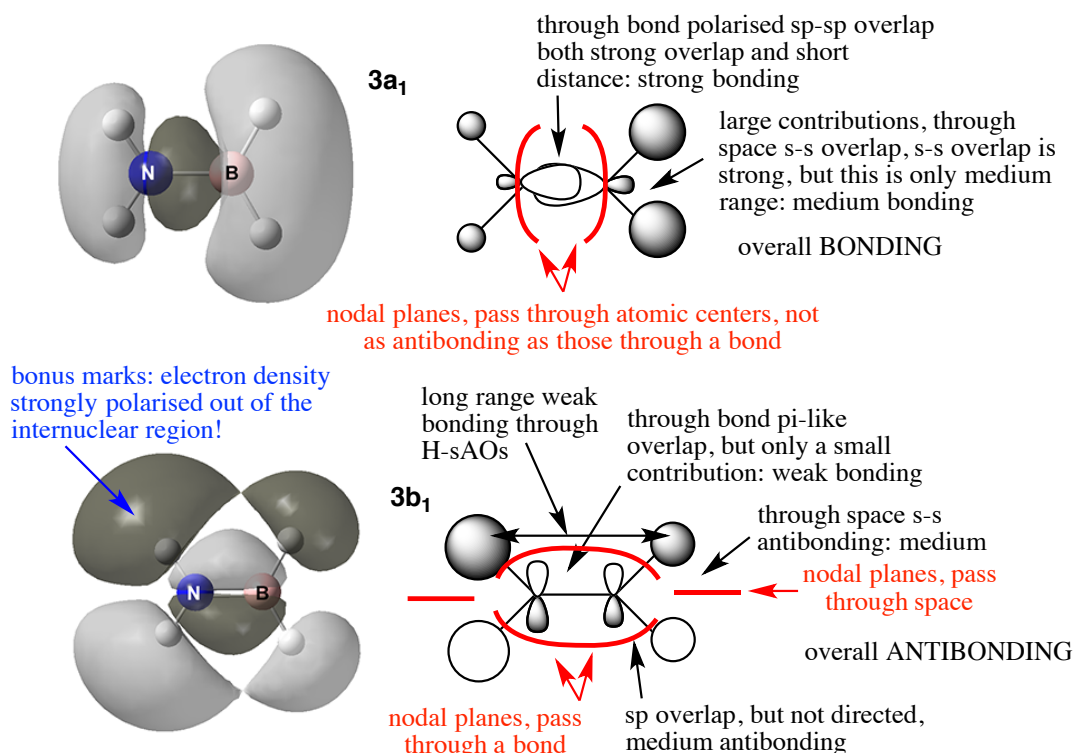

iv) **List** the MOs that contribute to the B-H σ -bonds, **explain** why you selected these MOs.
(4 marks)

B-H σ -bond, the occupied MOs: $2a_1$, $1b_1$, $3a_1$, $2b_1$, (**2 marks**) ie all occupied MOs with an orbital component on B and on the bonded H atoms. (**2 marks**) The $1a_1$ is on the NH_2 fragment and the $1b_2$ has no contributions from the BH_2 H atoms. The excited orbitals will also make small contributions but this has not been covered in this course.

Part b(i) requires problem solving in that the students have been shown how to construct MO diagrams, but they have not seen this particular example. Part b(ii) is partly problem solving, students have not seen these particular real MOs before, this question also requires the student to demonstrate more advanced understanding of the underlying concepts. Part b(iii) is problem solving and requires the student to demonstrate more advanced understanding on how to interpret the MO diagram.